

# LEGENDE

-  Emplacement Lave Linge
-  Emplacement Lave Vaisselle
-  Emplacement Lave Linge ou Lave Vaisselle
-  Emplacement Cuisson
-  Emplacement Réfrigérateur
-  Tableau Electrique
-  Panneau Rayonnant
-  Sèche Serviette
-  Baie Couissante
-  Porte Fenêtre
-  Fenêtre
-  Fenêtre à Allège Vitrée
-  Volet Roulant
-  Prise Télévision
-  Placard
-  Soffite / Faux Plafond
-  Gaine Technique
-  Chauffe Eau
-  Pompe à Chaleur
-  Attente Lave Linge supplémentaire
-  Groupe(s) Extérieur(s)
-  Module Thermique d'Appartement
-  Brasseur d'air

N

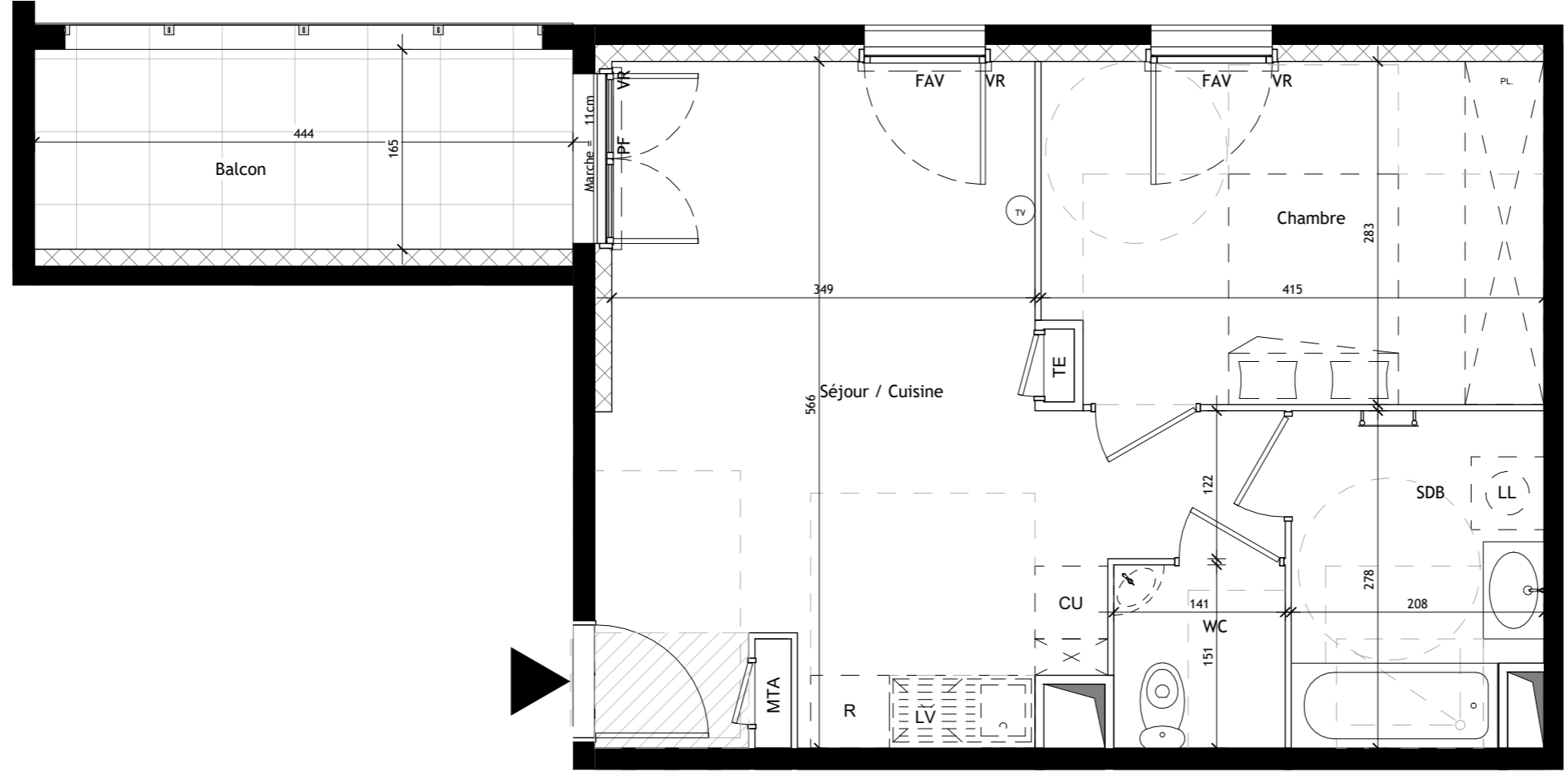

BÂTIMENT : B	Type : T2
Niveau : R+3	N° : B33

TABLEAU DES SURFACES	
Chambre	11.48 m <sup>2</sup>
SDB	5.53 m <sup>2</sup>
Séjour / Cuisine	23.86 m <sup>2</sup>
WC	2.13 m <sup>2</sup>
<b>SURFACE HABITABLE</b>	<b>43.00 m<sup>2</sup></b>
<b>Balcon</b>	<b>7.31 m<sup>2</sup></b>

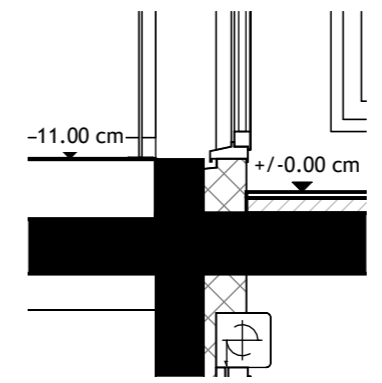
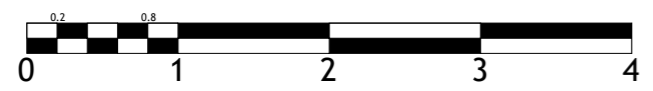

NOTA :

- Des modifications sont susceptibles d'être apportées à ce plan en fonction des nécessités techniques ou réglementaires lors de la réalisation
- Les surfaces indiquées sont approximatives conformément à l'article R261-25 du CCH
- Les retombées, soffites, faux plafonds, gaines, canalisations, convecteurs, l'emplacement des équipements électriques, ainsi que la hauteur sous plafond des seuils et la hauteur des seuils et allèges sont figurés à titre indicatif.
- Les plantations éventuelles ne sont pas contractuelles. Le mobilier ainsi que l'emplacement des éléments de cuisine et de la salle de bain sont donnés à titre indicatif et sont non contractuels.

## PLAN DE VENTE

SCCV EUREKA LOT 17B  
 1475 Av Albert Einstein  
 34000 Montpellier  
 07 57 60 98 14  
 contact@cocoonresidence.com

Indice : D	Date : 01/04/2026
------------	-------------------