





















**LEGENDE**

-  Emplacement Evier
-  Emplacement Cuisson
-  Emplacement Réfrigérateur
-  Emplacement LL/LV
-  Tableau Electrique
- VRE** Volet roulant électrique
-  Gaine technique
-  Soffite Faux Plafond
-  Cloison démontable
-  **PF** Porte fenêtre 3 vantaux dont un fixe
-  **PF** Porte fenêtre 2 vantaux
-  **PF** Porte fenêtre 1 vantail
-  **BF** Baie fixe
-  **FA** Fenêtre **Allege pleine**
-  **FV** Fenêtre **Allege vitrée**
-  Tablette
-  Panneau rayonnant
-  Sèche serviette
-  Prise TV
-  Attente LL supplémentaire
-  Brise Soleil

**PRINCIPE DE CHANGEMENT DE NIVEAU INT/EXT**

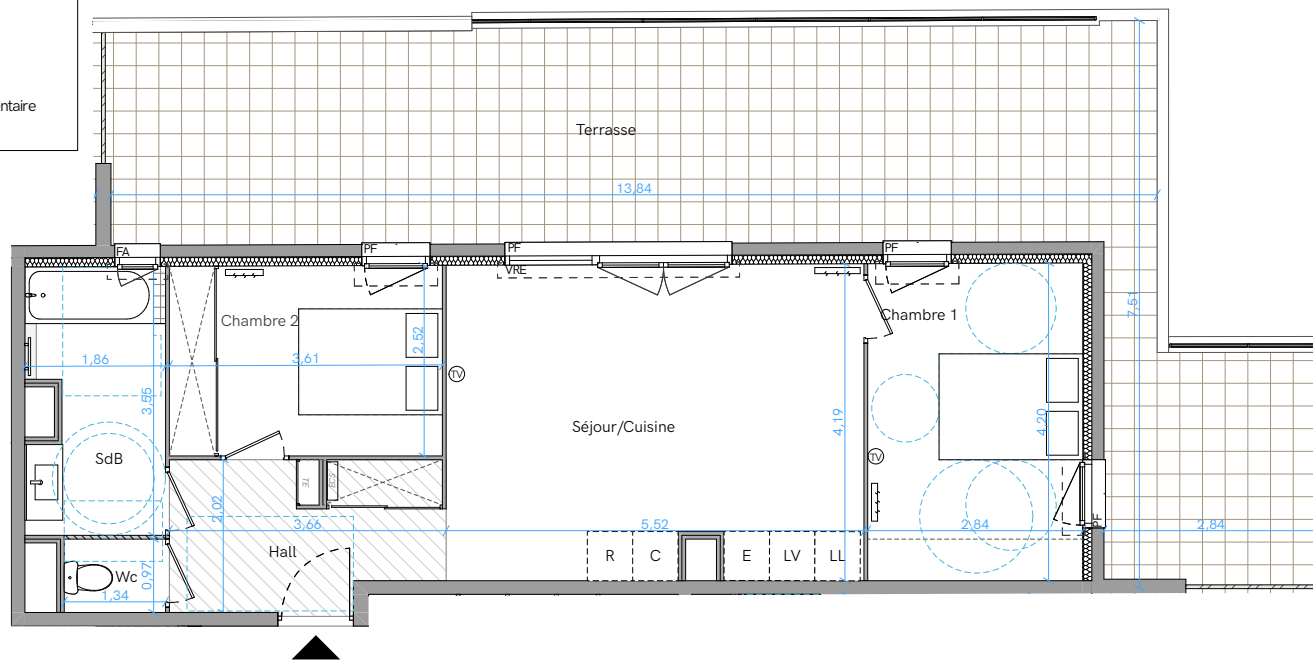
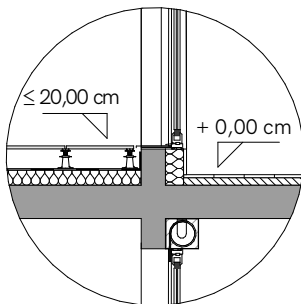

**NOTA :**

- Des modifications sont susceptibles d'être apportées à ce plan en fonction des nécessités techniques ou réglementaires lors de la réalisation.
- Les surfaces indiqués sont approximatives conformément à l'article R216-25 du CCH.
- Les retombées, soffites, faux-plafonds, trappes de visites, gaines, canalisations, convecteurs, l'emplacement des équipements électriques, ainsi que la hauteur sous plafond et la hauteur des seuils et allèges sont figurés à titre indicatif.
- Les plantations éventuelles ne sont pas contractuelles. Le mobilier ainsi que l'emplacement des éléments de cuisine et de salle de bains sont donnés à titre indicatif et sont non contractuels.



**PLAN DE VENTE**

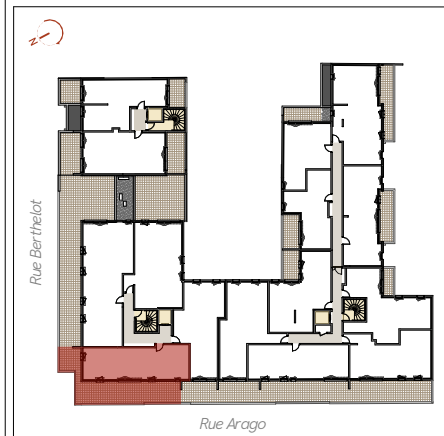

Niveau	Type	n° Appartement
R+3	T3	<b>B302</b>

TABLEAU DES SURFACES m <sup>2</sup>	
Séjour/Cuisine	24,9
Chambre 1	12,0
Chambre 2	9,1
Hall	4,5
SdB	6,2
Wc	1,3
<b>SURFACE HABITABLE</b>	<b>58,0</b>
Terrasse	49,2

